

Yanmar type 2YM15

The Powerful Gem

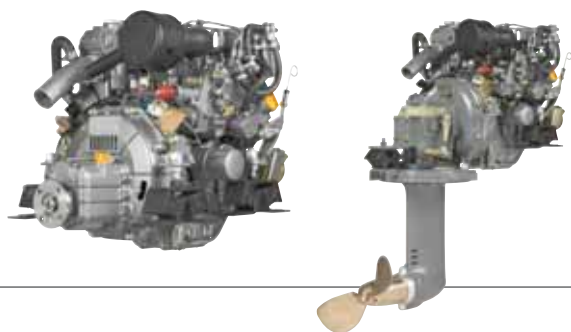

Configuration	4-stroke, vertical, water cooled diesel engine
Maximum output at crankshaft	* 10.3 kW (14 mhp) / 3600 rpm ** 10.0 kW (13.6 mhp) / 3600 rpm
Continuous rating output at crankshaft	9.4 kw (12.8 mhp) / 3489 rpm
Displacement	0.570 L (34.7 cu in)
Bore x stroke	70 mm x 74 mm (2.75 in x 2.91 in)
Cylinders	2
Combustion system	Indirect injection
Aspiration	Natural aspiration
Starting system	Electric starting 12 V - 1.4 kW
Alternator	12 V - 60 A
Cooling system	Fresh water cooling with heat exchanger
Lubrication system	Enclosed, forced lubricating system
Direction of rotation (crankshaft)	Counter clockwise viewed from stern
Dry weight without gear	103 kg (227 lbs)
Environmental	Meets the comprehensive emissions regulations introduced in EU and US (Tier II) in 2006
Engine mounting	Rubber type flexible mounts

NOTE: Fuel condition: Density at 15°C = 0.84 g/cm³; 1kW = 1.3596 mhp = 1.3410 HP

* Fuel temperature 25°C at the inlet of the fuel injection pump (ISO 3046-1)

** Fuel temperature 40°C at the inlet of the fuel injection pump (ISO 8665)

Technical data is according to ISO 8665 / 3046

Dimensions (For detailed line-drawings, please refer to our web-site: www.yanmarmarine.com or contact your supplier)

Rear view

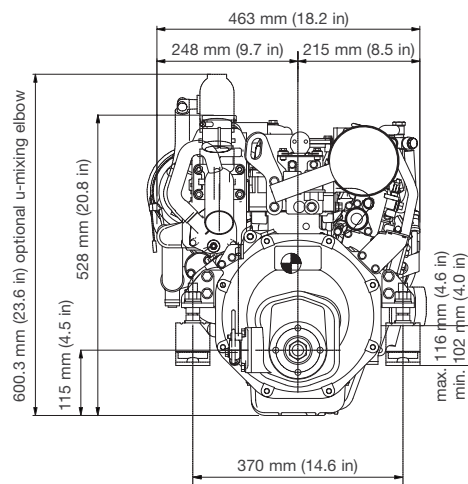

Right side view

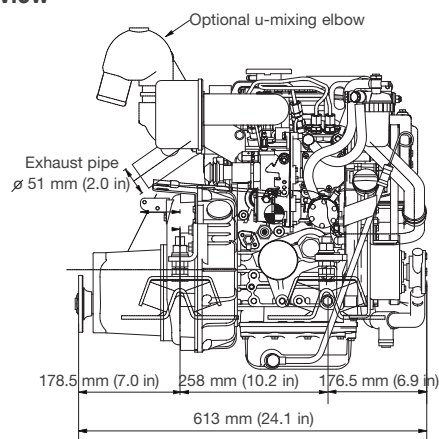

2YM15 w/ KM2P-1 marine gear

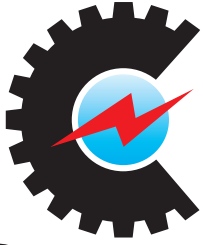

**Central
Diesel**

The Engine, Pump & Power Co.

Product Specification

Central Diesel provides these specifications as a courtesy and are a guide only. They have been sourced from the manufacturer and may change without notice. Central Diesel accepts no responsibility for any errors or omissions.

Performance Curves (Output is according ISO 8665)

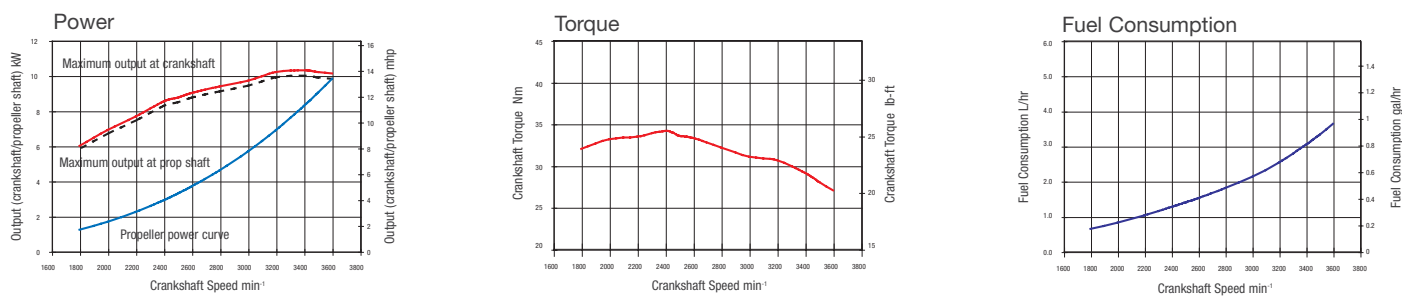

Marine Gears/Drive

Model	KM2P-1			Saildrive (SD20)
Type	Constant mesh gear with servo-cone clutch			Constant mesh gear with dog clutch
Dry weight	10 kg (22 lbs)			30 kg (66 lbs)
Reduction ratio (fwd/asn)	2.21/3.06	2.62/3.06	3.22/3.06	2.64/2.64
Propeller speed (fwd/asn)	1629/1164	1374/1164	1118/1164	1364/1364
Direction of rotation (propeller shaft - fwd)	Clockwise viewed from stern			Counter clockwise viewed from stern
Dry weight engine and gear/drive	113 kg (249 lbs)			134 kg (295 lbs)
Length engine and gear/drive	613 mm (24 in)			793 mm (31 in)

Instrument Panels

Digital B-type Panel

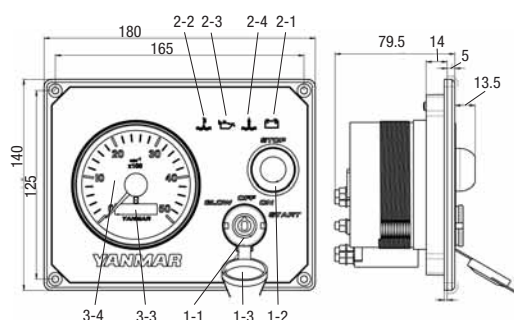

Function	Type of instrument panel
	Digital B-type Panel
① Switch unit	
1-1 Key switch for GLOW/OFF/ON/START (4-position switch)	O
1-2 Push button switch for engine stop	O
1-3 Moisture cap for key switch	O
② Alarm lamp unit	
2-1 Battery low charge alarm	O
2-2 Coolant high temperature alarm	O
2-3 Lubricating oil low pressure	O
2-4 Water in sail drive seal alarm	O
2-5 Water in fuel filter alarm	X
2-6 Sea water insufficient flow alarm	X
③ Meters	
3-1 Lubricating oil pressure meter	X
3-2 Coolant temperature meter	X
3-3 Hour meter	O
3-4 Tachometer	O
④ Audible alarm buzzer	O

Note: O = Equipped on panel X = Not equipped on panel

Accessories

Standard Package

- Set of flexible mounts
- Exhaust mixing elbow (L-type)
- V-belt safety cover
- Expansion tank for fresh water cooling system
- Alternator 12 V - 60 A
- Electric stop solenoid

Optional

- Additional Digital B-type instrument panel
- Primary 80 A alternator
- Exhaust mixing elbow, U-type (high riser)
- Various extension wire harnesses
- Hot water fittings

Texts and illustrations are not binding. Yanmar Marine reserves the right to introduce adaptations without prior notification.

2YM15 Version: 2006-03