



**Central
Diesel**

The Engine, Pump & Power Co.

Product Specification

Central Diesel provides these specifications as a courtesy and are a guide only. They have been sourced from the manufacturer and may change without notice. Central Diesel accepts no responsibility for any errors or omissions.



FIVE YEAR PUMP END WARRANTY ON ALL AUSSIE QUIK PRIME PUMPS

AUSSIE QUIK PRIME DIESEL DRIVE HIGH PRESSURE TRANSFER PUMPS

Model Numbers: **Aussie Brigade Boss Series**
QP310SL QP402SL
QP310SX QP402SX



QP402SL/OC95

Features

- Five year pump warranty
- Big closed single impeller
- Marine grade aluminium body
- Replaceable suction port
- Full roll frame with anti vibration mounts standard
- Economic and reliable Yanmar & Kubota diesel engines
- Exceptional efficiencies
- Optional viton seal kit
- Petrol engine drive versions also available (see separate spec sheet)
- Electric start standard
- Hydraulic drive option

Specifications

Model	Yanmar Option		Kubota Option		Max Head	Max Flow	Suction port	Discharge port	Self primes to
	Model	HP	Model	HP	(m)	(lpm)			(m)
QP310SL	L100E	10	OC95E	9.5	50	1150	4"	3"	8
QP310SX	L100E	10	OC95E	9.5	70	600	4"	3"	7.8
QP402SL	L100E	10	OC95E	9.5	50	1300	4"	4"	8
QP402SX	L100E	10	OC95E	9.5	70	700	4"	4"	7.8

Product Description:

3" and 4" pumps with high pressure, high flow characteristics. Pumps offer flows of up to 1,500 litres per minute, and heads of up to 70 metres. This series offers exceptional priming characteristics with the ability to draught water from 8 metres. Computer generated hydraulic design delivers superb fuel efficient performance through big single closed style impellers capable of handling small solids in suspension.

Applications:

- Fire fighting including village protection
- Fast fill tanker applications
- High pressure water transfer
- Wash and flush stock crate cleanout
- Tanker batter spray
- Construction site dust suppression
- High head dewatering

Benefits

- Great quality ... use with confidence
- Exceptional pump performance and fuel economy
- Corrosion resistant, longevity
- Easily replaced if thread damaged, easy to service check valve without dismantling pump
- Protects pump, facilitates transport on site
- Tried and proven with established service networks throughout the world
- Transfers more water per litre of fuel
- Permits pumping of diesel fuel or some ag chemicals
- Lighter option, makes it easier to carry
- For ease of starting
- Ideal for water cart applications, no separate engine, cuts service cost



Five Year Warranty:

Aussie Quik Prime pumps carry a unique pump end five year warranty. The products are guaranteed to be free of faulty workmanship or material for a period of five years after the date of sale to the end user.

Only top quality genuine brand engines by reputable Japanese manufacturers are used. A two year engine manufacturer's warranty applies, administered by the engine manufacturer or it's duly appointed representative. All engines used by Australian Pump Industries are major international brands, serviced and supported not only in Australia and South Pacific but right throughout the world.

Due to our program of continuous product development the manufacturer reserves the right to alter specifications without notice.





FIVE YEAR PUMP END WARRANTY ON ALL AUSSIE QUIK PRIME PUMPS

AUSSIE QUIK PRIME DIESEL DRIVE HIGH PRESSURE TRANSFER PUMPS

Model Numbers: **Aussie Brigade Boss Series**
QP310SL QP402SL
QP310SX QP402SX

Construction:

Front case	Marine grade aluminium
Volute	Marine grade aluminium
Back plate	Marine grade aluminium
Mechanical seal	Carbon/ceramic
Outlet	Marine grade aluminium
Casing bolts	Zinc plated steel
Check valve	Nitrile rubber
Priming & drain plugs	Polycarbonate
Casing, priming & drain plug orings	Nitrile rubber
Finish	Brushed aluminium
Impeller	Marine grade aluminium, closed type

Dimensions:

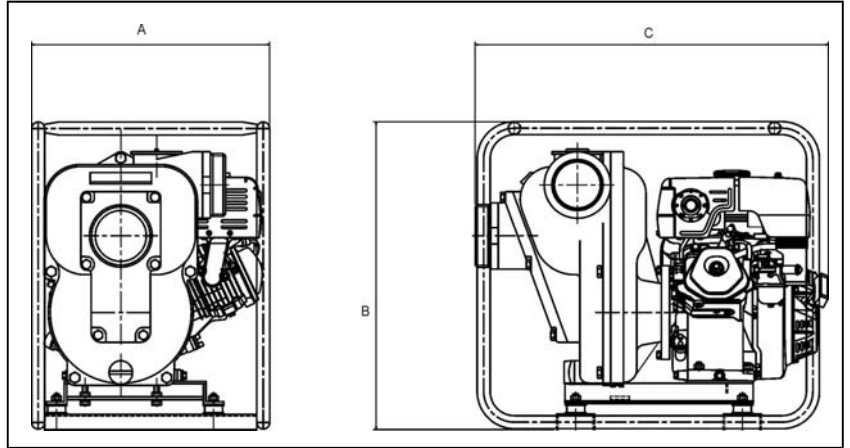

Model	Engine	A Width (mm)	B Height (mm)	C Length (mm)	Weight (kg)
QP310SL, QP310SX	L100	560	680	760	98
QP402SL, QP410SX	L100	560	680	760	98



QP402SL/L100

Standard Accessories:

- Coupling kit and strainer
- Full frame

Optional Accessories:

- Heavy duty suction hose, 3" & 4"
- Medium pressure and high pressure lay flat delivery hose
- High pressure fire fighting nozzles
- Full galvanised roll frame provided as standard equipment on all diesel engine drive versions or available for corrosive or extreme applications
- Monitor style stainless steel Unifire water canon
- Camlock couplings
- Hydraulic drive option

Performance Curve:

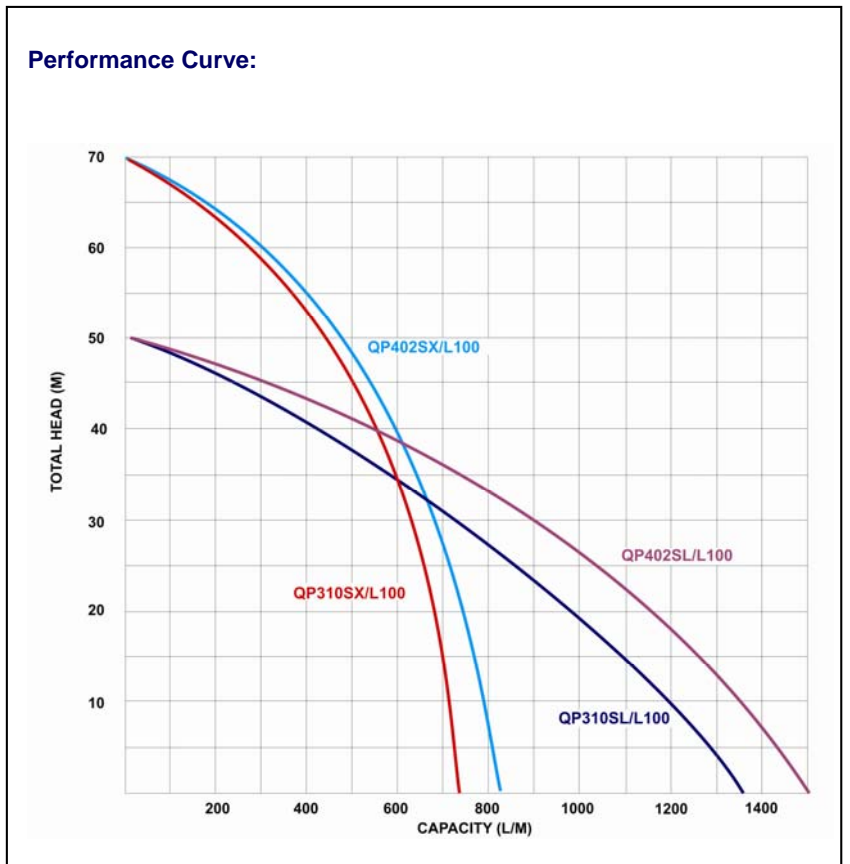

Performance details and curves are to be taken as a guide only.